

BAT500J

Battery Bank 500J for 12 & 24 Vdc applications

Instruction Manual

Thank you for having chosen one of our products for your work. We are certain that it will give the utmost satisfaction and be a notable help on your job and application.

1 Best Performance Battery Bank

Be carefully, for the device best performance, during the first connection, maintain the device connected to CB160 and main power present, for at least 2.5h. This to charge the battery above 80% of the capacity.

2 Product Description

Battery Bank for DC-UPS "All In One". Lithium-ion technology maintenance-free, designed to provide emergency power backup in the field of Industrial, domotic and domestic applications. Suitable for 12V or 24V systems. Simple connection with screw terminals for Wall mount or DIN rail. The device integrates CAN protocol communication to exchange all data on ADELBUS.

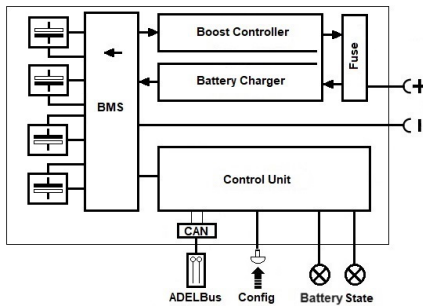

3 Safety and warning notes

To safely operate this Battery Bank please read and follow all instructions carefully. Read this manual thoroughly before attempting to unpack, install or operate. Please refer to section 7 for a complete information about safety.



WARNING – Explosion hazard: do not disconnect equipment unless power has been switched off or the area is known to be non-hazardous.

WARNING – Explosion hazard. Replacement of components may impair suitability for class I, Division 2.

WARNING – Switch off the system before connecting the module. Never work on the machine when it is live. The device must be installed according to EN61010 and EN62368-1

WARNING – The device is equipped with an internal fuse. If the internal fuse blows up (fails opens), most probably there is a fault in the device. If this failure occurs, the device must be returned to the factory.

4 How to Install

4.1 Mounting

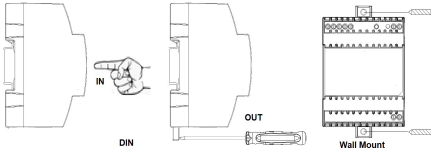

Fig. 1 – Mounting of the BAT12Wh

4.2 Din Rail or Panel Mounting

Fig. 1 shows the mounting of the BAT12Wh. It is possible to mount the device on DIN rail or on panel and fix it by 4 screws 2.9x8-16. There is no limit for the panel thickness.

4.3 How to connect the Battery Bank

The device is supplied directly from the power source which provides power to recharge the battery bank and receives power from the battery bank in backup mode. The device is protected by an internal physical fuse, also in worst case situations. The input rating is 8 – 35Vdc.

4.4 Device Connection (Fig.2)

The following cable cross-sections may be used:

	Solid (mm ²)	Stranded (mm ²)	AWG	Torque (Nm)	Stripping Length
In:	0.2–2.5	0.2–2.5	24 – 14	0.5–0.6	7 mm
Out:	0.2–2.5	0.2–2.5	24 – 14	0.5–0.6	7 mm
Signal:					AMP Modu II

Screw type terminals, 2.5 mm². Wiring shall be marked to indicate the proper connection for the power supply. Use copper cables only; for power connections use wires suitable for at least 75°C

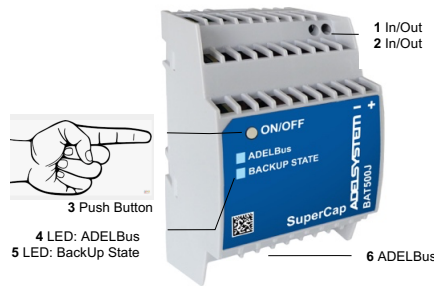

Fig. 2 –Battery Bank connections

4.5 Connection terminal and wiring

Reference	Description
1	+ Positive Pole
2	- Negative Pole
3	Push Button: <ul style="list-style-type: none"> • Press once to turn ON: LED 5 GREEN blinking • Long press to turn OFF, until LED 5 ORANGE blinks quickly, then release and Leave
4	ADELBUS LED for CAN communication
5	LED For the Capacity State
6	ADELBUS connection (AUX1)

5 Use the Battery Bank

5.1 Wiring Diagram

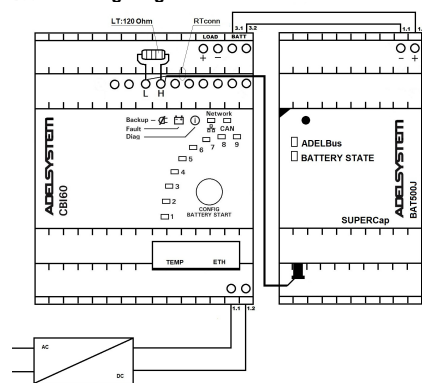

Fig. 3 –Connect to DC Ups

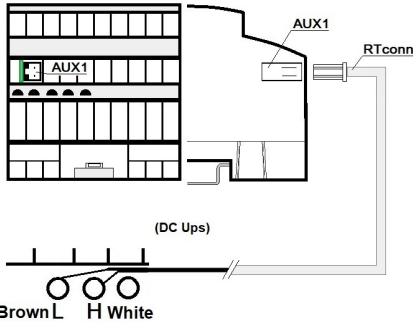

Fig. 4 –Connection RTConn cable

To ADELBUS connection, please connect the cable RTConn on AUX1 as explained in Fig.4 and connect the other side of the cable to the CAN terminals L (Brown) and H (White) of the DC UPS, with a line termination (LT) resistor 120 Ohm, present inside the cable kit.

5.2 First time configuration

When used for the first time the device must be connected to a power source and is automatically configured for 12V or 24V output voltage. The actual setting can be checked as follows:

- Turn off the Battery Bank
 - Press the button and keep it pressed; the LED 5 will stay ON solid:
 - RED: output voltage not set => the device must be started with external power
 - GREEN: output voltage set to 12V
 - ORANGE: output voltage set to 24V
- (see "reset to factory" procedure to change the output voltage)

If the DC-UPS supports the ADELBUS on CAN, the following procedure must be carried out when connected for the first time to a Battery Bank:

- Make sure that the ADELBUS is properly connected and that both the Battery Bank and the DC UPS are switched OFF
- Turn ON the DC-UPS by supplying AC power
- Note: if the battery bank is completely discharged and does not start, keep its button pressed while starting the DC-UPS and continue to keep the button pressed
- Wait until the CAN LED is solid green on both devices

5.3 LED Indication

Status	Message	LED 5 Battery State
Charging mode status	Float	GREEN 1 Blink/2 sec
	Absorption	GREEN 1 Blink/sec
	Bulk	GREEN 2 Blinks/sec
	Recovery	GREEN 5 Blinks/sec
Back Up	Running from battery	ORANGE slow flashing
	Battery low	ORANGE fixed ON
Low Input voltage	Input voltage should be at list 12.5V or 25V to start charging	ORANGE 5 Blinks
Alarm	Overload or short circuit	RED 4 Blinks/pause
	<ul style="list-style-type: none"> • Connect the Battery Bank to CBI60 • Initializing internal BMS until battery cells are connected. If this alarm persists, Battery may be faulty 	RED 5 Blinks/pause
	<ul style="list-style-type: none"> • Internal device failure 	RED 7 Blinks/pause
	Battery temperature sensor faulty	RED 12 Blinks/pause
	Battery overtemperature	RED 15 Blinks/pause

Status	Message	LED 4 ADELBUS
ADELBUS	CAN Active	GREEN Solid or Flashing
ADELBUS	Awaiting configuration	RED / GREEN Flashing
ADELBUS	CAN bus Error	RED Solid

5.4 Reset to factory procedure

- Turn on the device from battery with a "click and long press" of the button, like a "double click" but the second time the button must remain pressed
- If the "click and long press" of the button was done correctly the Battery State LED will blink in GREEN slowly (once a second): keep the button pressed
- After 5 seconds the Battery State LED will blink RED quickly. Keep the button pressed for 10 seconds more.
- Note: if the button is released within 10 seconds, the device will turn in "bootloader mode" with the Battery Status LED fixed ON and the ADELBUS LED will flickering RED and GREEN. If this happens, click the button to turn off the device and repeat the procedure
- After 10 seconds the Battery State LED will stay fixed ON: release the button, the device will restore the factory settings and turn off.

6 Functionality of BMS

- All critical parameters of the battery system SuperCap (such as cell temperature, voltages, currents, etc.) are monitored cyclically by the Battery Management System (BMS) for compliance with the limits and the battery system is shut down in the event of a fault. Charging and discharging is only possible with an active battery management system.

6.1 Protection functions

The BMS has a large number of parameters for detecting fault conditions:

- Overcharge
- Over discharge
- Discharge overcurrent
- Charge overcurrent
- Load short-circuit

When the BMS detects a fault condition the internal battery is disconnected and can be reactivated only by applying external power. In this case the LED may indicate a temporary battery fault (5 blinks) for about 30 seconds.

7 Technical Data

7.1 Please refer to the product data sheet

8 Accessory

- RTConn: connector cable for the connection to AUX1. This is needed for data exchange with the DC UPS through the ADELBUS (if supported by the DC UPS).
- Line Terminator 120 Ohm present inside the Kit of the RTConn.

Codice campo modificato